

**Fabric Switch Board -
3U OpenVPX (VITA 65)
PCI Express (VITA 46.4)
and Ethernet (VITA 46.6)**

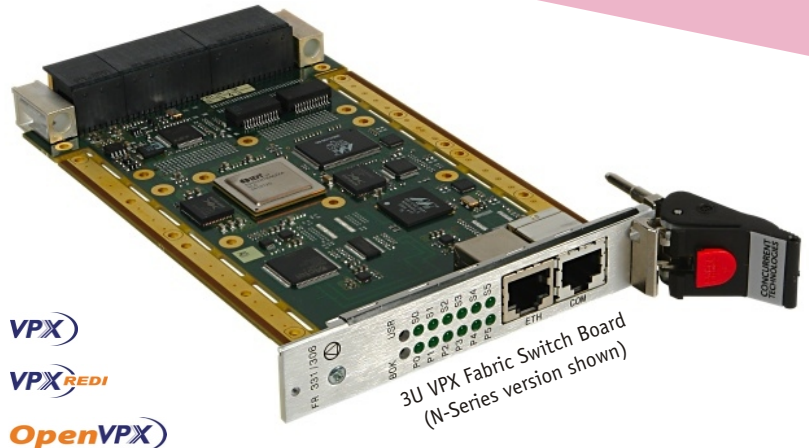

APPLICATIONS

The FR 331/306 is a 3U OpenVPX fabric switch board with a x4 PCI Express™ data plane (VITA 46.4) and a 1000 Base-BX control plane (VITA 46.6), for use in VPX or VPX-REDI PCI Express Backplane environments. The FR 331/306 supports six payload boards with options for Ethernet and RS232 user control connections via the front panel. The FR 331/306 is suitable for use in centralized switching systems as defined in OpenVPX™

(VITA 65). The FR 331/306-RCS is a VPX-REDI Type 1 Two-Level Maintenance conduction-cooled board and the FR 331/306-RCT is VPX-REDI Type 2. Typical applications include networking equipment, data management and blade-based servers in vertical markets such as defense, communications, medical and automation.

HIGHLIGHTS

- 3U VPX-REDI (VITA 48.0) RCx-Series switch fabric board:
 - conduction-cooled to VITA 48.2
 - conformally coated
 - -40°C to +85°C operating temperature
 - RCS-Series supports VPX-REDI Type 1 Two Level Maintenance in 3U VPX-REDI 0.85-inch slot
 - RCT-Series supports VPX-REDI Type 2 in 3U VPX-REDI 0.8-inch slot
- 3U VPX (VITA 46.0) N-Series switch fabric board:
 - rear I/O compatible with the VPX-REDI RCx-Series
 - air-cooled
 - 0°C to +55°C operating temperature
 - use in commercial (non-rugged) applications
 - 3U VPX 0.8 inch slot
- 3U OpenVPX (VITA 65) fabric switch board:
 - compatible with a range of OpenVPX profiles
- 3U OpenVPX fabric switch board:
 - for use in PCI Express™ Backplane environments
 - supporting six payloads
 - x4 PCI Express (Gen 1 or Gen 2) data plane (VITA 46.4)
 - utilizing non-transparent/transparent PCI bridges
 - supports DMA on any two PCI Express ports
 - 1000 Base-BX unmanaged control plane (VITA 46.6)
- Switch configuration using serial terminal via front panel or rear panel:
 - Fabric Switch Configuration software
- Non-volatile EEPROM storage for:
 - board configuration data
 - both PCI Express and Ethernet switch configuration data
- Gigabit Ethernet port via rear panel and optional Gigabit Ethernet port via front panel

VPX (-REDI) Fabric Switch Board

- ruggedized 3U VPX-REDI (RCx-Series) PCI Express™ fabric switch board:-
 - conduction-cooled (VITA 48.2)
 - conformally coated
- non-ruggedized VPX (N-Series) version:-
 - commercial air-cooled
- compatible with range of OpenVPX (VITA 65) module profiles

Data Plane Switch

- 6-port VITA 46.4 data plane switch board:-
 - for use with PCI Express Fabric backplanes
 - x4 PCI Express links
 - support for Gen 1 or Gen 2
 - transparent and non-transparent bridge functionality on each port
- supports two DMA engines which can be assigned to any of the six ports:-
 - any two assigned ports can use DMA
- EEPROM storage for switch configuration data

Control Plane Switch

- 6-port VITA 46.6 control plane switch board:-
 - for use with VITA 46.6, unmanaged 1000 Base-BX control plane
- high performance IEEE 802.1 switch:-
 - implemented by Marvell® Prestera™ 98DX106 single-chip switch
 - full line rate Layer 2 switching engine
 - 8K MAC address cache with automatic learning and aging
- EEPROM storage for switch configuration data

System Management Hardware

- on-board System Management Controller:-
 - implemented by microcontroller
 - supports dual 8 Kbytes non-volatile memory for inventory details of board
 - implements SM0-1 used for IPMI management

Switch Configuration Setup

- PCI Express switch and Ethernet switch configuration setup interface using RS232 serial port:-
 - implemented by microcontroller
 - switch initialization
 - separate EEPROM for storing PCI Express configurations
 - separate EEPROM for storing Ethernet configurations
- RS232 serial port options:-
 - front panel, VPX N-Series
 - rear panel, VPX-REDI RCx-Series
- Fabric Switch Configuration software:-
 - see separate SW FSC/001 datasheet

Switch Status Indicators

- front panel, VPX N-Series only:-
 - Link/Activity LEDs for all VPX backplane 1000 Base-BX ports
 - LinkUp/Active status LEDs for all PCI Express ports

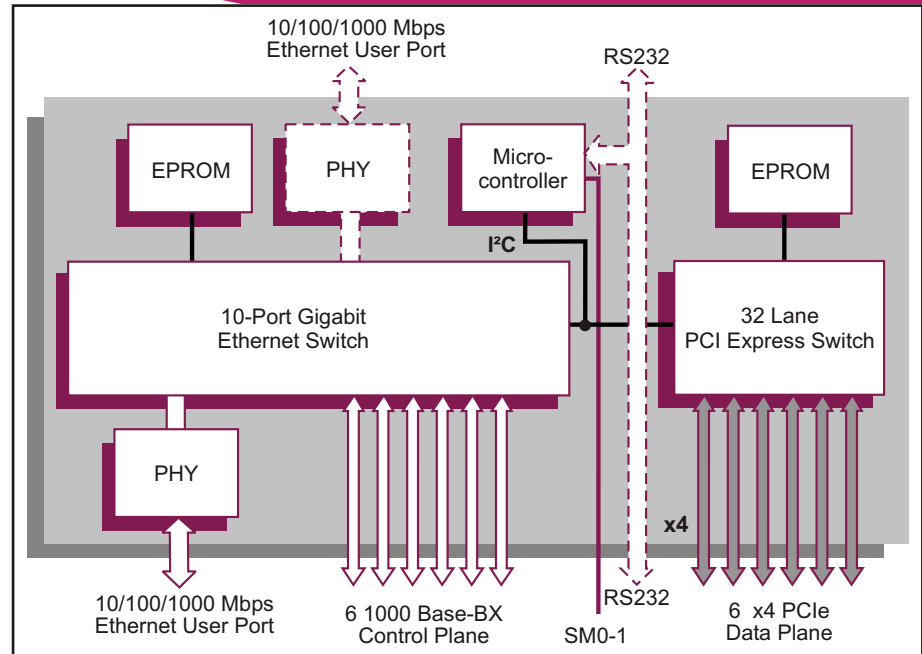

Ethernet Interfaces

- Gigabit Ethernet user port via front panel, VPX N-Series
- Gigabit Ethernet user port via rear panel, VPX N-Series and VPX-REDI RCx-Series

Electrical Specification (estimated)

- typical current figures
- +5V@ 4A, voltage +5% / -3%
- +3.3V@ 1.5A, voltage +5% / -3%

Environmental Specification

- operating temperature, VPX N-Series:-
 - VITA 47 Class AC1, 0°C to +55°C
 - useful for bench development
 - air-cooled
- storage temperature, VPX N-Series:-
 - VITA 47 Class C1, -40°C to +85°C
- operating altitude, VPX N-Series: 0 to 15,000 feet (0 to 4,572 meters)
- operating temperature, VPX-REDI RCx-Series:-
 - VITA 47 Class CC4, -40°C to +85°C
 - conduction-cooled (VITA 48.2)
- storage temperature, VPX-REDI RCx-Series:-
 - VITA 47 Class C4, -55°C to +105°C
- operating altitude, VPX-REDI RCx-Series: -1,000 to 50,000 feet (-305 to 15,240 meters)
- 5% to 95% Relative Humidity, non condensing* (operating/storage for N-Series and RCx-Series)

Mechanical Specification

- 3U VPX form-factor (VITA 46.0, VITA 48.0): 3.9 inches x 6.3 inches (100mm x 160mm)
- slot widths, N-Series and RCx-Series:-
 - 0.8 inches VPX N-Series (VITA 46.0)
 - 0.8 inches VPX-REDI Type 2, RCT-Series (VITA 48.0)
 - 0.85 inches VPX-REDI Type 1, RCS-Series (VITA 48.0). Where REDI Type 1 is Two Level Maintenance (VITA 48.2)
- connectors to VITA 46.0 for P0, P1 and P2
- operating mechanical, VPX N-Series:-
 - shock - VITA 47 Class OS1, 20g
 - vibration - 0.002g²/Hz
- operating mechanical, VPX-REDI RCx-Series:-
 - shock - VITA 47 Class OS2, 40g
 - random vibration - VITA 47 Class V3, 0.1g²/Hz

Safety

- PCB (PWB) manufactured with flammability rating of 94V-0



ORDERING INFORMATION

Order Number	Product Description (Hardware)
FR 331/306-11	6-port PCI Express Fabric Switch, 3U VPX, RS232 via front panel, N-Series
FR 331/306-13RCS	6-port PCI Express Fabric Switch, 3U VPX-REDI Type 1, RS232 via rear panel, RCS-Series
FR 331/306-13RCT	6-port PCI Express Fabric Switch, 3U VPX-REDI Type 2, RS232 via rear panel, RCT-Series

SW FSC/001-L0 Fabric Switch Configuration Tool

For accessories please contact your local sales office. For further information on the VPX and VPX-REDI boards please contact your local sales office.