

PMC730 Multi-function I/O

- Analog Input
- Analog Output
- Digital I/O
- Counter/Timer

PMC730 mezzanine modules provide a variety of I/O functions on a single plug-in card. These new high-density modules perform both high-speed and high-resolution A/D and D/A conversion and also handle digital I/O and counter/timer functions.

Now you can conserve your precious PMC slots and still get all the I/O functionality you need. The PMC730 is designed for extreme versatility with many deluxe features to meet most applications. However, the PMC730 is still very budget-friendly. A conduction-cooled version is also available.

Features

Analog Inputs

- 16 differential or 32 single-ended inputs ($\pm 3.3V$, $\pm 5V$, $\pm 10V$, $0-5V$, and $0-10V$ ranges)
- 16-bit ADC with 512 sample RAM
- $10\mu s$ conversion time (100KHz)
- Interrupt upon ADC memory threshold condition (user-programmable data sample threshold)
- User-programmable interval timer

Analog Outputs

- Eight analog output channels ($\pm 10V$ range)
- Individual 16-bit DACs per channel
- 1024 sample FIFO for waveform generation
- $12.375\mu s$ settling time (80.8KHz throughput)
- Interrupt on user-programmable FIFO threshold

Digital I/O

- 16 TTL bidirectional input/outputs

Counter/Timer

- One 32-bit counter/timer

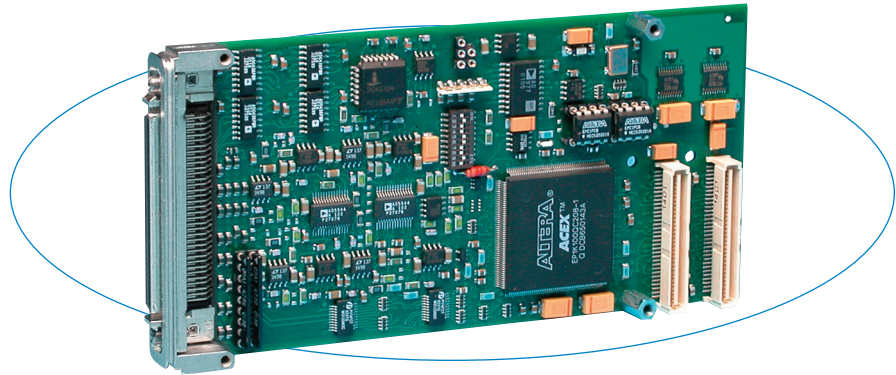

The PMC730 combines analog I/O, digital I/O, and counter/timer functions on a single high-density module to save PMC slots.

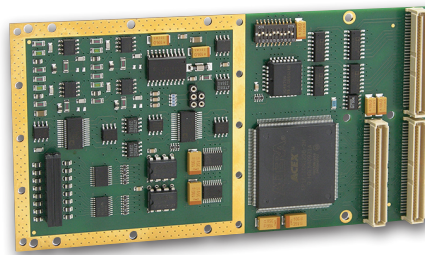

PMC730CC for conduction cooling.

Specifications

Analog Input

Input configuration: 16 differential or 32 single-ended channels multiplexed to a single A/D converter.

A/D resolution: 16 bits.

Input ranges: $\pm 3.3V$, $\pm 5V$, $\pm 10V$, $0-5V$, and $0-10V$.

Maximum throughput rate:

One channel updated at a time.

1 channel (maximum): $10\mu s$

16 channels (maximum): $160\mu s$

32 channels (maximum): $320\mu s$

Data sample memory: 512 samples shared by all channels.

A/D trigger: Internal timer, external source, software.

On-board timer: One user-programmable timer for analog input acquisition control.

System accuracy: ± 3 LSB typ. (SW calib., gain=1, 25°C).

Data format: Straight binary or binary two's complement.

Input overvoltage protection: -40 to $55V$ power off.

Common mode rejection ratio (60Hz): 96dB typical.

Channel-to-channel rejection ratio (60Hz): 96dB typical.

Analog Output

Output configuration: 8 single-ended channels, each controlled by its own independent D/A converter.

D/A resolution: 16 bits.

Output range: $\pm 10V$.

Maximum throughput rate:

Outputs updated simultaneously or individually.

1 channel: $12.375\mu s$

8 different channels: $12.375\mu s$

DAC programming: Via independent channel registers or through shared FIFO.

Data sample memory: 1024 sample FIFO shared by all channels.

D/A trigger: Internal timer, external source, software.

On-board timer: One user-programmable timer for analog output control.

System accuracy: 0.0076% of 20V span max. error corrected (i.e. calibrated) at 25°C with output unloaded.

Data format: Straight binary.

Output at reset: 0V.

Output current: -10 to $10mA$ (maximum).

Short circuit protection: Indefinite at 25°C.

Digital I/O

I/O channel configuration: 16 TTL transceivers, input/output direction selectable on an 8-channel basis.

Digital Input

Input voltage range: 0 to 5V DC.

Input signal threshold:

Low to high: 2.0V typical.

High to low: 0.8V typical.

Input response time: 250 nanoseconds.

Interrupts: 16 channels of interrupts for high-to-low, low-to-high, or any change-of-state event types.

Debounce: Individual debounce selectable on each channel. User-selectable ($4\mu s$, $64\mu s$, $1ms$, or $8ms$).

Digital Output

Output voltage range: 0 to 5V DC.

Output ON current range: -15 to $64mA$.

Output pullups: 4.7K ohm socketed resistors.

Counter/Timers

Counter/timer configuration: one 32-bit counter (requires use of channels 2 through 5 of digital I/O section).

Functions:

Watchdog timer, event counting, pulse measurement, period measurement, output waveform generation (pulse width modulation, continuous pulse, single pulse, continuous waveform).

Continued on the next page.

All trademarks are the property of their respective owners.

Block Diagram

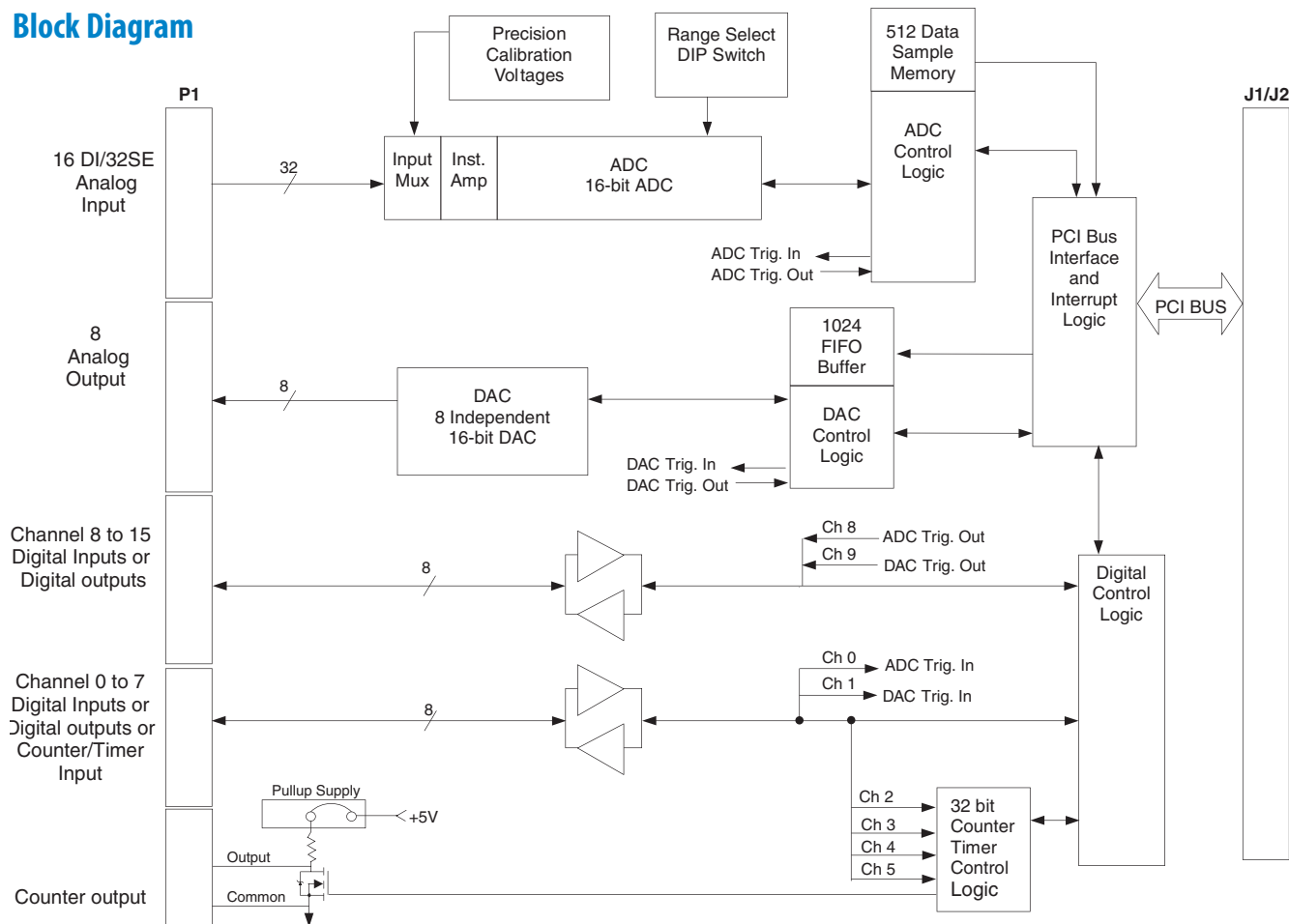

Specifications (continued)

Counter/Timers

Continued from the previous page.

Internal clock: Programmable 1, 4, 8MHz.

External clock: 3.4MHz.

Input voltage range: 0 to 5V DC.

Output voltage range: 0 to 5V with 4.7 ohm pull-up.
Maximum of 0 to 35V with external supply.

PMC Compliance

Conforms to PCI Local Bus Specification, Revision 2.2 and CMC/PMC Specification, P1386.1.

4K Memory Space Required: One Base Address Register.

Signaling: 5V Compliant, 3.3V Tolerant.

Interrupts (INTA#): Interrupt A is used to request an interrupt.

Environmental

Operating temperature: 0 to 70°C (PMC730 / R) or -40 to 85°C (PMC730E / CC)

Storage temperature: -55 to 100°C.

Relative humidity: 5 to 95% non-condensing.

Power: 120mA at +5V. 95mA at +12V. 70mA at -12V.

MTBF: 929,541 hrs. at 25°C, MIL-HDBK-217F, notice 2.

Ordering Information

PMC Modules

PMC730

Multi-function I/O module with front I/O connector

PMC730E

Same as PMC730 plus extended temperature range

PMC730R

Multi-function I/O module with rear I/O connector

PMC730CC

Multi-function I/O module, plus extended temperature range and onduction-cooled with rear I/O connector

Software (see [software documentation](#) for details)

PMCSW-API-VXW

VxWorks® software support package

PCISW-API-QNX

QNX® software support package

PCISW-API-WIN

Windows® DLL Driver software package

PCISW-LINUX

Linux™ support (website download only)

Accessories (see [accessories documentation](#) for details)

5025-288

Termination panel, SCSI-3 connector, 68 screw terminals.

5028-432

Cable, shielded, SCSI-3 connector both ends.



All trademarks are the property of their respective owners.