

PMC424 Digital I/O (Differential & TTL) and Counter/Timers

The PMC424 digital I/O module provides 24 differential input/outputs, 16 TTL input/output channels, and four 16-bit multi-function counter/timers.

The 16 TTL input/output channels can be programmed as an input or an output on a channel basis. The 24 differential input/output channels are programmed as inputs or outputs on an 4-channel port basis. All input channels can be enabled for change of state, low, or high level transition interrupts.

Four 16-bit multifunction counters/timers can be configured for pulse width modulated output, watchdog timer, event counter, frequency measurement, pulse width measurement, period measurement, or one shot pulse output. The four 16-bit counters can also be configured into two 32-bit counter/timers. A conduction-cooled version is also available.

Features

Digital I/O

- 40 digital input/output channels:
 - 24 differential input/outputs
 - 16 TTL input/output channels (15 ch. for 434R)
- Programmable change of state/level interrupts
- Input signal filtering debounce logic

Counter/Timer

- Four 16-bit or two 32-bit counter/timer channels (control lines shared with 16 TTL I/O channels)
- Six operating modes:
 - Pulse width modulation
 - Watchdog timer
 - Event counter
 - Frequency measurement
 - Pulse width or period measurement
 - One-shot and repetitive one-shot
- TTL-compatible thresholds
- Power-up and system reset are failsafe

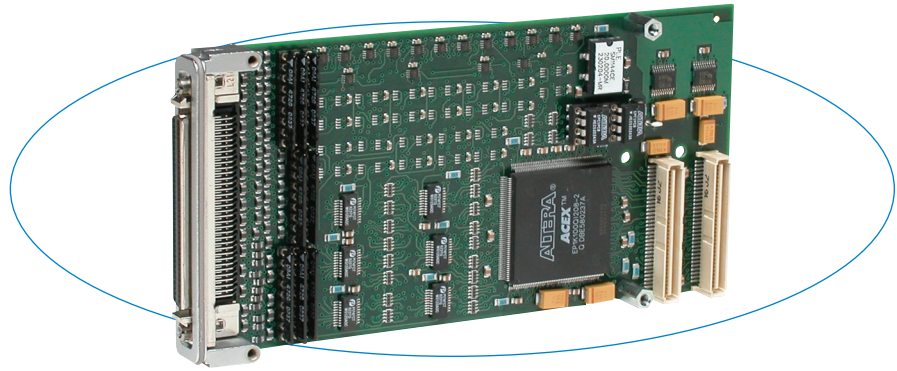

This module saves money and PMC slots by combining differential I/O, TTL I/O, and counter/timer functions on one card.

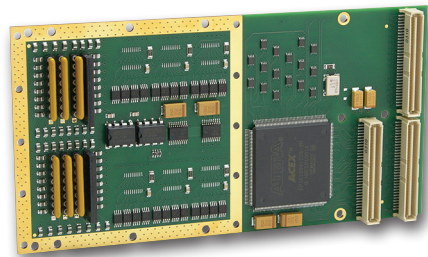

PMC424CC for conduction cooling

Specifications

Differential Digital I/O

I/O channel configuration: 24 bidirectional non-isolated RS485/422A differential signals. Direction is controlled as a 4-channel group.

Differential driver output voltage with 50 ohm load: 2V minimum, 5V maximum.

Common mode output voltage: 3V maximum:

Minimum input resistance: 12K ohms.

Termination resistors: 120 ohm termination resistor networks are installed in sockets.

TTL Digital I/O

I/O channel configuration: 16 bidirectional TTL (15 for 424R) transceivers with direction controlled independently (shared as counter/timer control signals).

Reset/power-up condition: All channels default to input.

Digital Input

Input voltage range: 0 to 5V DC.

Input signal threshold, low to high: 3.5V typical.

Input signal threshold, high to low: 1.5V typical.

Input response time: 10 nanoseconds, typical.

Digital Output

Output voltage range: 0 to 5V DC.

Output ON current range: -32 to 32mA.

Output pullups: 4.7K ohm socketed resistors.

Turn on time: 10nS.

Turn off time: 10nS.

Input Interrupts

40 channels of interrupts are available for high-to-low, low-to-high, or any change-of-state event type.

Debounce: Selectable for each channel. User-selectable (5.6µS, 50.4µS, 408.8µS, or 3.276mS).

Counter/Timers

Counter/timer configuration: Four 16-bit counters can be configured into two 32-bit counters.

Counter input: Each counter has an IN_A, IN_B, and IN_C port. These TTL input signals control start/stop, reload, event input, external clock, trigger, and up/down operations.

Counter output: Each counter has one output signal. The TTL output is used for waveform output, watchdog active indicator, or 1.6µS pulse upon counter function completion. Programmable as active high or low.

Clock frequencies: Selectable for 20MHz, 10MHz, 5MHz, 2.5MHz, 1.25MHz or external up to 8MHz.

Minimum I/P event: 100nS (debounce disabled).

Minimum pulse measurement: 100nS (debounce disabled).

Minimum period measurement: 200nS (debounce disabled).

Minimum gate/trigger pulse: 100nS (debounce disabled).

Board crystal oscillator: 20MHz.

PMC Compliance

Conforms to PCI Local Bus Specification, Revision 2.2 and CMC/PMC Specification, P1386.1.

4K Memory Space Required: One Base Address Register.

Signaling: 5V Compliant, 3.3V Tolerant.

Environmental

Operating temperature: 0 to 70°C (PMC424 / R) or -40 to 85°C (PMC424E / CC)

Storage temperature: -55 to 105°C.

Relative humidity: 5 to 95% non-condensing.

MTBF: 1,596,123 hrs. at 25°C, MIL-HDBK-217F, notice 2.

Power: 216mA at +5V, typical.

Continued on the next page.

All trademarks are the property of their respective owners.

Block Diagram

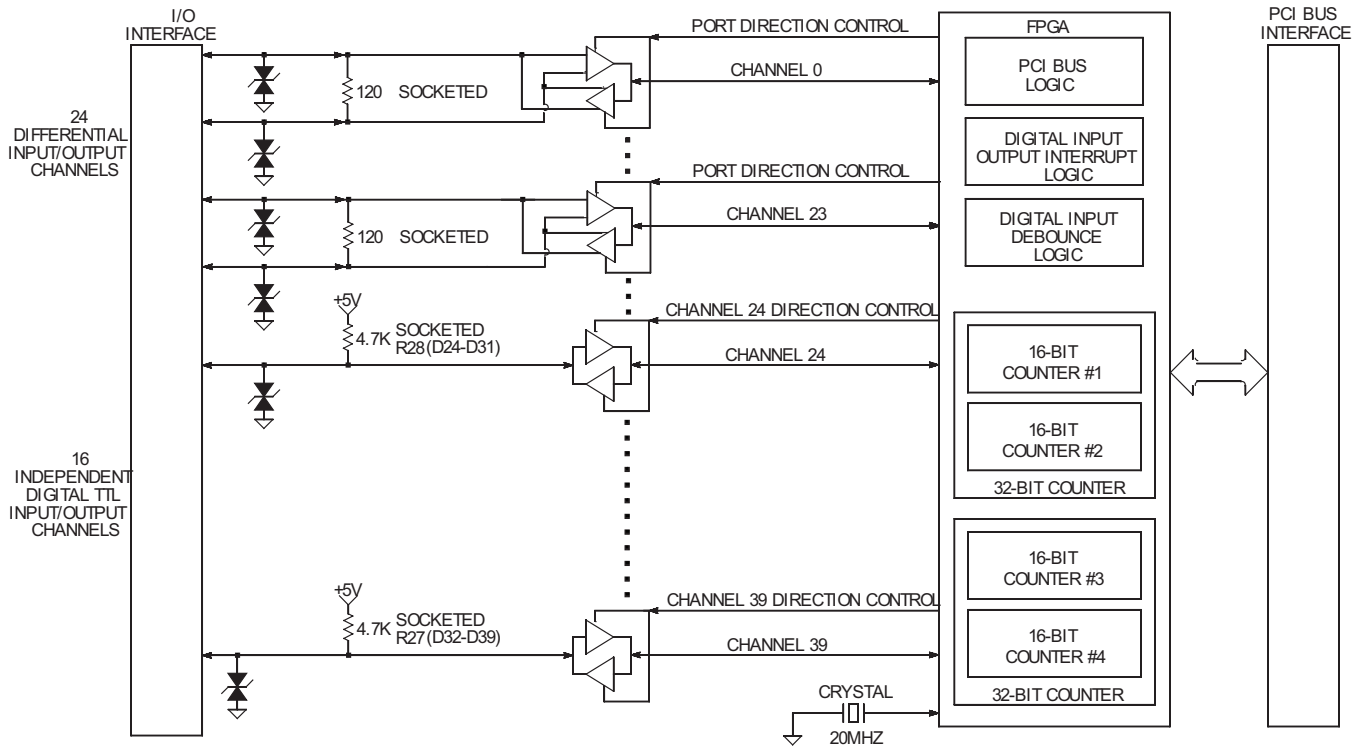

Ordering Information

- PMC424:** Digital I/O and counter/timer module
- PMC424E:** Same as PMC424 plus extended temp. range
- PMC424R:** Digital I/O and counter/timer module with rear I/O connector.
- PMC424CC:** Digital I/O and counter/timer module, extended temperature range and conduction-cooled with rear I/O connector.

- Software** (see [software documentation](#) for details)
- PMCSW-API-VXW:** VxWorks[®] software support package
 - PCISW-API-QNX:** QNX[®] software support package
 - PCISW-API-WIN:** Windows[®] DLL software support
 - PCISW-LINUX:** Linux[®] support (website download only)

- Accessories** (see [accessories documentation](#) for details)
- 5025-288:** Termination panel, SCSI-3 connector, 68 screw terminals
 - 5028-432:** Cable, shielded, SCSI-3 connector both ends



All trademarks are the property of their respective owners.