

## AcPC730 Multi-function I/O

- Analog Input
- Analog Output
- Digital I/O
- Counter/Timer

AcPC730 I/O boards provide a variety of I/O functions on a single card. These new high-density boards perform both high-speed and high-resolution A/D and D/A conversion and also handle digital I/O plus counter/timer functions.

Now you can conserve your precious card slots and still get all the I/O functionality you need. The AcPC730 is designed for extreme versatility with many deluxe features to meet most applications. However, the AcPC730 is still very budget-friendly.

### Features

#### Analog Inputs

- 16 differential or 32 single-ended inputs ( $\pm 3.3V$ ,  $\pm 5V$ ,  $\pm 10V$ ,  $0-5V$ , and  $0-10V$  ranges)
- 16-bit ADC with 512 sample RAM
- $10\mu S$  conversion time (100KHz)
- Interrupt upon ADC memory threshold condition (user-programmable data sample threshold)
- User-programmable interval timer

#### Analog Outputs

- Eight analog output channels ( $\pm 10V$  range)
- Individual 16-bit DACs per channel
- 1024 sample FIFO for waveform generation
- $12.375\mu S$  settling time (80.8KHz throughput)
- Interrupt on user-programmable FIFO threshold

#### Digital I/O

- 16 TTL bidirectional input/outputs

#### Counter/Timer

- One 32-bit counter/timer

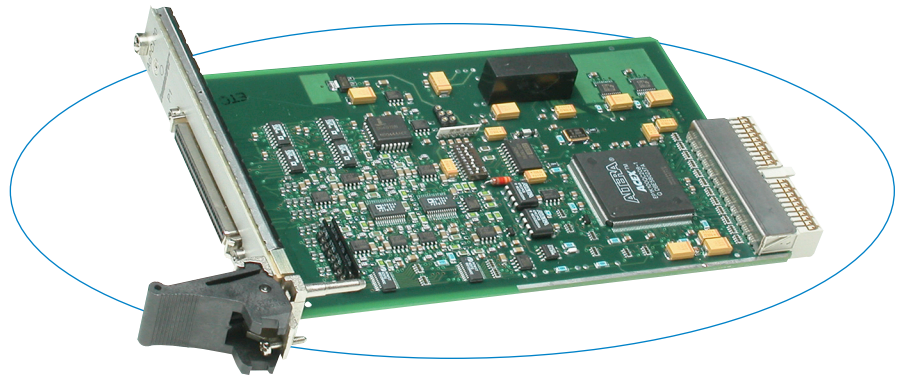

The AcPC730 combines analog I/O, digital I/O, and counter/timer functions on a single high-density module to save cPCI slots.

### Specifications

#### Analog Input

Input configuration: 16 differential or 32 single-ended channels multiplexed to a single A/D converter.

A/D resolution: 16 bits.

Input ranges:  $\pm 3.3V$ ,  $\pm 5V$ ,  $\pm 10V$ ,  $0-5V$ , and  $0-10V$ .

Maximum throughput rate:

One channel updated at a time.

1 channel (maximum):  $10\mu S$

16 channels (maximum):  $160\mu S$

32 channels (maximum):  $320\mu S$

Data sample memory: 512 samples shared by all channels.

A/D trigger: Internal timer, external source, software.

On-board timer: One user-programmable timer for analog input acquisition control.

System accuracy:  $\pm 3$  LSB typ. (SW calib., gain=1,  $25^\circ C$ ).

Data format: Straight binary or binary two's complement.

Input overvoltage protection:  $-40$  to  $55V$  power off.

Common mode rejection ratio (60Hz): 96dB typical.

Channel-to-channel rejection ratio (60Hz): 96dB typical.

#### Analog Output

Output configuration: 8 single-ended channels, each controlled by its own independent D/A converter.

D/A resolution: 16 bits.

Output range:  $\pm 10V$ .

Maximum throughput rate:

Outputs updated simultaneously or individually.

1 channel:  $12.375\mu S$

8 different channels:  $12.375\mu S$

DAC programming: Via independent channel registers or through shared FIFO.

Data sample memory: 1024 sample FIFO shared by all channels.

D/A trigger: Internal timer, external source, software.

On-board timer: One user-programmable timer for analog output control.

System accuracy: 0.0076% of 20V span max. error corrected (i.e. calibrated) at  $25^\circ C$  with output unloaded.

Data format: Straight binary.

Output at reset: 0V.

Output current:  $-10$  to  $10mA$  (maximum).

Short circuit protection: Indefinite at  $25^\circ C$ .

#### Digital I/O

I/O channel configuration: 16 TTL transceivers, input/output direction selectable on an 8-channel basis.

#### Digital Input

Input voltage range:  $0$  to  $5V$  DC.

Input signal threshold:

Low to high:  $2.0V$  typical.

High to low:  $0.8V$  typical.

Input response time:  $250$  nanoseconds.

Interrupts: 16 channels of interrupts for high-to-low, low-to-high, or any change-of-state event types.

Debounce: Individual debounce selectable on each channel. User-selectable ( $4\mu S$ ,  $64\mu S$ ,  $1mS$ , or  $8mS$ ).

#### Digital Output

Output voltage range:  $0$  to  $5V$  DC.

Output ON current range:  $-15$  to  $64mA$ .

Output pullups:  $4.7K$  ohm socketed resistors.

#### Counter/Timers

Counter/timer configuration: one 32-bit counter (requires use of channels 2 through 5 of digital I/O section).

Functions:

Watchdog timer, event counting, pulse measurement, period measurement, output waveform generation (pulse width modulation, continuous pulse, single pulse, continuous waveform).

Internal clock: Programmable 1, 4, 8MHz.

External clock: 3.4MHz.

Input voltage range:  $0$  to  $5V$  DC.

Output voltage range:  $0$  to  $5V$  with  $4.7$  ohm pull-up. Maximum of  $0$  to  $35V$  with external supply.

Continued on the next page.

All trademarks are the property of their respective owners.

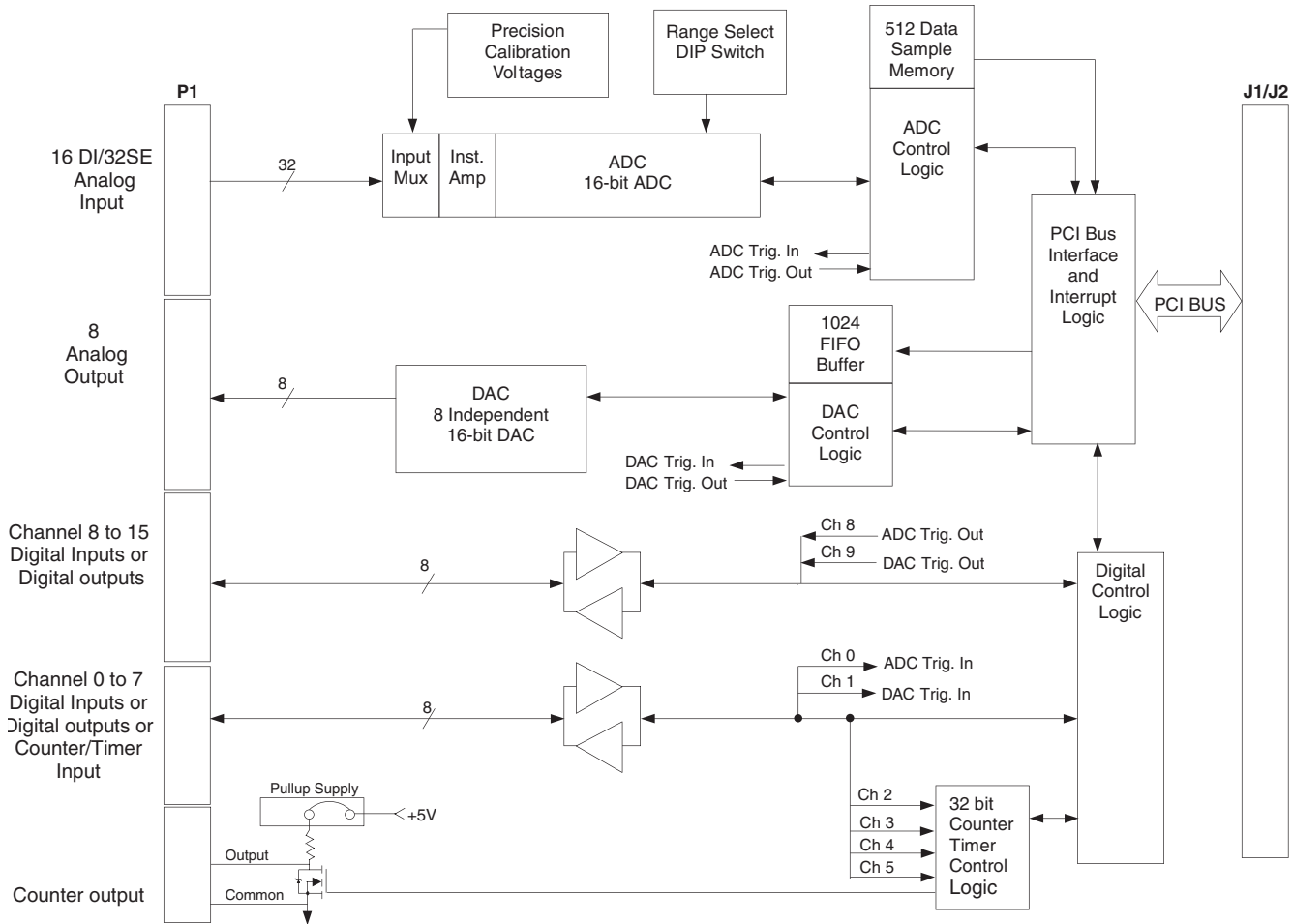

## Specifications (continued)

### CompactPCI bus Compliance

Meets PCI spec. V2.1 and PICMG 2.0, R3.0.

Data transfer bus: Slave with 32-bit, 16-bit, and 8-bit data transfer operation 32-bit read/write accesses are implemented as two 16-bit transfers.

Interrupts (INTA#): Interrupt A is used to request an interrupt.

Plug-and-Play: The system maps the base address into the PCI bus 32-bit memory space.

### Environmental

Operating temperature: 0 to 70°C  
(E version -40 to 85°C)

Storage temperature: -40 to 85°C.

Relative humidity: 5 to 95% non-condensing.

Power: 245mA at +5V (290mA maximum).

MTBF: Consult factory.

## Ordering Information

### I/O Boards

#### AcPC730

Multi-function I/O board

#### AcPC730E

Same as AcPC730 plus extended temperature range

### Software (see [software documentation](#) for details)

#### PMCSW-API-VXW

VxWorks® software support package

#### PCISW-API-QNX

QNX® software support package

#### PCISW-API-WIN

Windows® DLL Driver software package

#### PCISW-LINUX

Linux® support (website download only)

### Accessories (see [accessories documentation](#) for details)

#### 5025-288

Termination panel, SCSI-3 connector, 68 screw terminals

#### 5028-432

Cable, shielded, SCSI-3 connector at both ends



All trademarks are the property of their respective owners.