

Extension I/O Modules

PRELIMINARY
20111118
DATA
SUBJECT
TO
CHANGE
INFORMATION

24 HR
STOCK ITEM

AXM-A75 Multi-function I/O extension module for Acromag FPGA cards

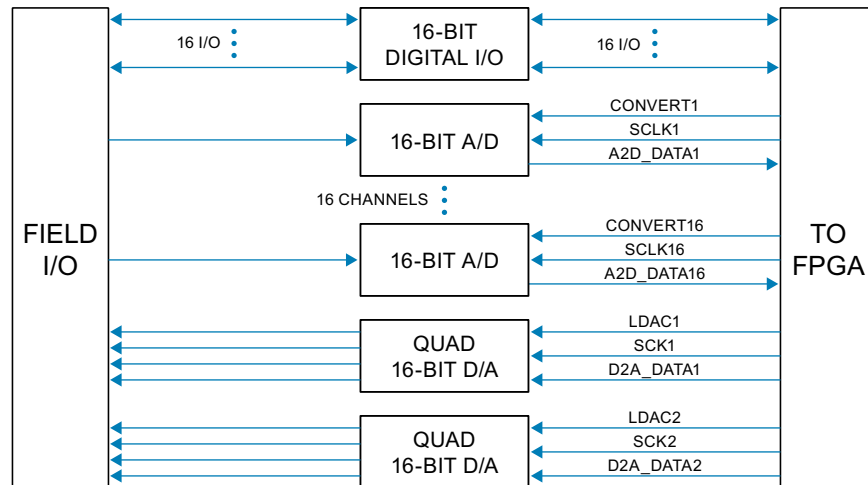
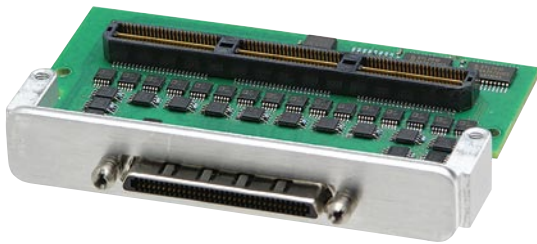

16 analog inputs, simultaneous A/D ♦ 8 analog outputs, simultaneous D/A ♦ 16 digital I/O channels

Description

The AXM-75 is a multi-function I/O module that adds A/D, D/A, and digital I/O signal processing functions to an FPGA board. These extension I/O modules plug directly onto many Acromag reconfigurable FPGA cards equipped with an AXM mezzanine connector.

Analog Input

There are sixteen differential analog input channels on the AXM-A75. Each input has its own high-speed 16-bit A/D converter offering the ability to simultaneously sample all channels.

At the beginning of the analog signal chain is a low-pass filter to remove any unwanted EMI. A programmable gain instrumentation amplifier scales the input and provides giga-ohm input impedance. Serial FLASH memory is included to store factory calibration constants.

Analog Output

Two quad serial input DAC devices drive eight analog output channels. Each channel has its own high-speed 16-bit D/A converter allowing simultaneous updates to all outputs.

Digital I/O

Sixteen bi-directional digital I/O channels provide the ability to monitor and control discrete devices. Each I/O channel is individually configurable as an input or output for great flexibility to match your requirements

Key Features & Benefits

- 16 channels of analog input capable of simultaneous sampling
- 16-bit 250kHz A/D converter on each channel
- Analog input range of ± 10.24 volts
- Programmable gain of 1x, 2x, 4x, or 8x
- 8 channels of analog output capable of simultaneous updates
- Each A/D channel includes a 2K sample FIFO
- FIFO status interrupts configurable for half-full or overflow conditions
- Dual quad 16-bit serial input D/A converters with 10 μ s settling time
- Analog output range of ± 10 volts
- 16 channels of general-purpose digital I/O
- Front panel 68-pin VHDCI receptacle for field I/O connections
- Example VHDL code provided in the base board's Engineering Design Kit to control sample rate and gain selection



AXM extension I/O modules plug into a mezzanine connector on many Acromag FPGA boards to provide additional I/O signal processing capabilities.

RedLinX™
Embedded Solutions
www.redlinx.co.za

Acromag®
THE LEADER IN INDUSTRIAL I/O

Tel 248-295-0310 ■ Fax 248-624-9234 ■ solutions@acromag.com ■ www.acromag.com ■ 30765 Wixom Rd, Wixom, MI 48393 USA

Extension I/O Modules

20111118
PRELIMINARY
DATA
SUBJECT
TO
CHANGE
INFORMATION

AXM-A75 Multi-function I/O extension module for Acromag FPGA cards

Performance Specifications

■ Analog Input

Input configuration

16 differential channels with a separate A/D converter on each channel.

A/D resolution

16 bits.

Input range

±10.24 volts.

Programmable gain

1x, 2x, 4x, or 8x.

Input impedance

1 giga-ohm.

Maximum throughput rate

4 μ S A/D (250kHz).

A/D trigger

FPGA controlled.

Signal-to-noise ratio

69dB (25°C) typical.

Signal-to-noise and distortion

67dB (25°C) typical.

■ Analog Output

Output configuration

8 channels with a separate D/A converter for each channel provided by two quad serial input DACs. Double buffering allows the simultaneous updating of all channels.

D/A resolution

16 bits.

Output range

±10 volts.

Settling time

10 μ S (100kHz).

■ Digital I/O

I/O configuration

16 bi-directional I/O channels, individually configured.

I/O range

5V TTL.

Output type

Open collector type with open drain outputs.

Pull-up resistor

Digital I/O lines are pulled high via a 4.75k ohm resistor to +5 volts.

■ Physical

Acromag AXM I/O modules plug into a PMC or XMC FPGA module's front mezzanine for additional I/O lines. Analog and digital I/O AXM modules are sold separately.

Size

12.7 mm high x 42.1 mm deep x 74.0 mm wide (0.500 inches x 1.659 inches x 2.913 inches).

Stacking height

5.0 mm (0.315 in).

Weight

41.3 g (1.46 oz).

Connectors

I/O: 68-pin VHDCI receptacle.

Mezzanine: High-speed 150-pin header.

■ Environmental

Operating temperature

-40 to 85°C.

Storage temperature

-55 to 125°C.

Relative humidity

5 to 95% non-condensing.

Power

Specifications not yet available. Contact factory.

3.3V (±5%): ?? mA typical, 840mA maximum.

+12V (±5%): ?? mA typical, 804mA maximum.

-12V (±5%): ?? mA typical, ?? mA maximum.

5V (±5%): ?? mA typical, ?? mA maximum.

MTBF

Contact the factory.

Electromagnetic Compatibility (EMC)

Minimum immunity per European Norm EN61000-6-2:2005.

Electrostatic Discharge (ESD) Immunity

4KV direct contact and 8KV air-discharge to the enclosure port per IEC61000-4-2.

Radiated Field Immunity (RFI)

10V/m, 80 to 1000MHz AM; 3V/m, 1.4 to 2.0GHz;

1V/m, 2.0 to 2.7GHz, per IEC61000 4 3.

Electrical Fast Transient Immunity (EFT)

2KV to power, and 1KV to signal I/O per IEC61000-4-4.

Conducted RF Immunity (CRFI)

10Vrms, 150KHz to 80MHz, per IEC61000-4-6.

Surge Immunity

0.5KV to power and 1KV to signal per IEC61000-4-5.

Emissions

Per European Norm EN61000-6-4:2007.

Radiated Frequency Emissions

30 to 1000MHz per CISPR16 Class A.

Ordering Information

■ AXM Plug-In I/O Extension Modules

For more information, see www.acromag.com.

AXM-A75

16 analog inputs, 8 analog outputs, and 16 digital I/O

AXM-??

Custom I/O configurations available, call factory.

■ Accessories

For more information, see www.acromag.com.

5028-420

Cable, VHDCI 68-Pin to SCSI-3 MD68, 2 meters

5028-288

Termination panel

ISO9001
AS9100

MADE IN USA

RedLinX[™]
Embedded Solutions
www.redlinx.co.za

Acromag [®]
THE LEADER IN INDUSTRIAL I/O

Tel 248-295-0310 ■ Fax 248-624-9234 ■ solutions@acromag.com ■ www.acromag.com ■ 30765 Wixom Rd, Wixom, MI 48393 USA